

⚠ Warning

Read Safety Information before using the meter.

Summarize

The meter is a handled, battery-operated tool for measuring electrical parameters. It has all the features of a digital millimeter and measure AC voltage, DC voltage, AC current, DC current, resistance, capacitance, frequency, duty cycle ratio, dBm, TC, RTD, **Diode Test**, and **Continuity Check**.

Besides, it has features like:

- Large LCD screen could display the three characteristic of one input signals.
- Different reference impedance for dB measure function.
- AUTO HOLD, DISPLAY HOLD and PEAK HOLD to display the measuring value.
- Panel calibration function.
- Three convenient data recording modes: LOG mode, MANUAL mode, and COMP mode.
- USB-IR jack to connect with a PC

Open-case Inspection

Open the case to check, if the meter is damaged or something is missing, contact the place of purchase immediately. Contact the distributor for information about DMM accessories.

Accessories: A copy of user's manual

A set of CF-733370 industrial test lead

One USB to UART Bridge Controller (USB_DMM)

DMMVIEW_A disk

Options: K-TYPE TC

Safety Information

The meter complies with IEC61010.1-93 Over voltage II Pollution Degree 2. Use the meter only as specified in this manual. Otherwise, the protection provided by the meter may be impaired.

A **Warning** identifies conditions and actions that pose hazards to the user.

A **Caution** identifies conditions and actions that may damage the meter or the equipment under test.

A **Notice** identifies symbols of the operation and explanations of the features. International symbols used on the meter and in this manual are explained in Table 1-1.

⚠ Warning

To avoid possible electric shock or personal injury, follow these guidelines.

- **Use the meter as the instructions of the producer; otherwise, the protective function shall be invalid.**
- **Do not use the meter if it is damaged. Before you use the meter, inspect the case. Look for cracks or missing plastic. Pay particular attention to the insulation surrounding the connectors.**
- **Take the leads off the meter before unlock the battery door.**
- **Inspect the test leads for damaged insulation or exposed metal. Check the test leads for continuity. Replace damaged test leads before you use the meter.**
- **Do not use the meter if it operates abnormally. Protection may be impaired. When in doubt, have the meter serviced.**
- **Do not operate the meter around explosive gas, vapor, or dust.**
- **Do not apply more than the rated voltage, as marked on the meter, between terminals or between any terminal and earth ground.**
- **Make sure the meter works normally as per testing a known voltage. Do not use the meter if it operates abnormally. When in doubt, have the meter serviced.**
- **To avoid possible electric shock caused by false reading due to existing alternating voltage in all the direct current functions, including manual and auto ranging, make sure whether there is any alternating voltage existing or not before selecting a direct voltage range equals to or higher than the alternating voltage.**
- **To avoid false readings, which could lead to possible electric shock or personal injury, replace the batteries as soon as the low battery indicator  appears.**
- **Do not touch the exposed wire, connector or unused input jack or circuit under test when the meter is working.**
- **Use only type AAA batteries, properly installed in the meter case to power the meter.**
- **Use caution when working above 30 V ac rms, 42 V peak, or 60 V dc. Such voltages pose a shock hazard.**
- **Avoid working alone.**
- **When using the probes, keep your fingers behind the finger guards on the probes.**
- **Connect the common test lead before you connect the live test lead. When you disconnect test leads, disconnect the live test lead first.**
- **To avoid possible fire or electric shock, do not connect TC with the live circuit.**

⚠ Caution

To avoid possible damage to the meter or to the equipment under test:









- **Set the rotary switch on the right range. Do not cut off the testing leads and circuit before switching. Forbid to switch during the measuring process.**

- **Cut off the power and complete discharge before measuring resistance, continuity, diodes, or capacitance with the live circuit.**
- **Before measuring current, check the meter’s fuses (see Chapter 6 “Testing the Fuses”). Turn power OFF to the circuit before connecting the meter to the circuit. Remember: Plug the meter with the circuit when measuring current and do not connect test lead in parallel with any circuit.**

Symbols

Symbols used on the meter and in this manual are explained in Table 1-1.

Table 1-1. International Electrical Symbols

Symbols	Meaning	Symbols	Meaning
	Alternating current		Earth ground
	Direct current		Fuse
	Alternating and direct current		Double insulated
	Important information		Battery
CAT II	CAT II Overvoltage(Installation) Category II, Pollution Degree 2 per IEC61010 refers to the level of Impulse Withstand Voltage protection provided. Typical locations include: plug and the connecting electric equipments, home appliance, convenient tools, domestic plug, plugs 10m distant from type 3 circuit 20m distant from type 4 circuit.		

Chapter 2 Getting Acquainted

Introduction

Study this chapter to be acquainted with all the features and functions of the meter.

Turning the Meter On

To turn the meter on, press  to power on and press  again for more than 2 seconds to power off.

When the power is turned on, the source starts to make self-diagnosis internally and displays on full screen. After this, appropriate operation should be carried out.

⚠Attention



Power-on: To ensure the correct operation of the meter with power on. It is good practice to turn off the power supply pausing 5 seconds, and then restart the meter.

Automatic Power Off

The meter will go into automatic power-off mode if you have not changed the rotary switch position or pressed a button for a set period.

The automatic power off is preset to 10 minutes. From the Setup menu (see Chapter 5” Changing the Default Settings”), users can decide whether they want to use the function of the automatic power-off or not.

Backlight On

To turn the backlight on, press  to turn on and press  again to turn off.

Automatic backlight off

The automatic backlight off is preset to 30s. If user doesn’t turn off backlight within 30s, the meter will turn off backlight automatically. From the Setup menu (see Chapter 5” Changing the Default Settings”), users can decide whether they want to use the function of the automatic backlight off or not.

Low Battery Indicator

The battery indicator  in the upper right corner of the display notifies you that the batteries are low and should be replaced.

⚠Warning

To avoid false readings, which could lead to possible electric shock or personal injury, replace the batteries as soon as the battery indicator  appears.

If the battery indicator  appears, it will lead to the shut-up of the storage function.

Outer Structure

See Figure 2-1.

Input Jack

Figure2-2 and Table2-1 explain the input jacks.

Rotary Switch

Figure2-3 and Table2-2 explain the measuring functions of the rotary function switch positions.

Display Unit

Figure 2-4 and Table 2-3 explains the meaning of the every displaying unit.

Communication interface

You could use the USB_DMM and the DMMVIEW_A software to transfer the content stored in the meter and real time measuring value to a PC.(See Chapter 4” Using Memory & Communications Features”)

Pushbutton

Figure2-5 and Table 2-4 show the pushbutton function.

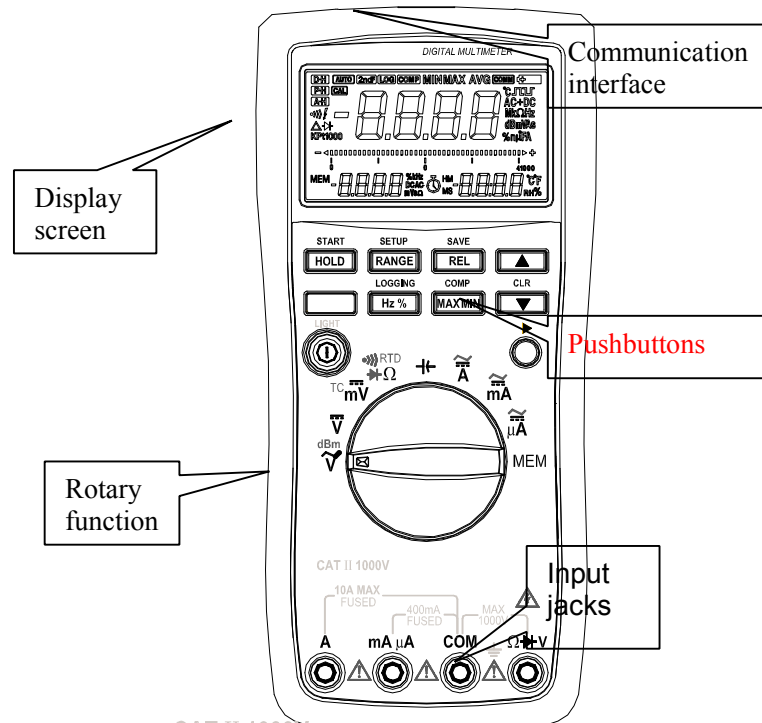

Figure 2-1. Outer Structure

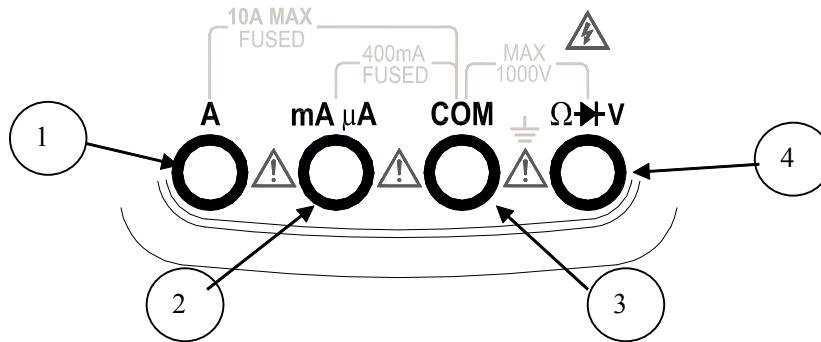

Figure 2-2. Input Jacks

Table 2-1. Input Jacks

Item	Function
①	Measuring Signal (+): direct and alternating current (A), frequency.
②	Measuring Signal (+): direct and alternating current (mA, μ A), frequency
③	Public (return) Jacks of all the measurement (-)
④	Measuring Signal (+): direct voltage, direct mV voltage, alternating voltage, resistance, diodes, continuity, frequency, RTD, TC, CAP

Fig 2-3. Rotary Switches
Table 2-

re 2-3. Rotary Switches
2. Rotary Switches

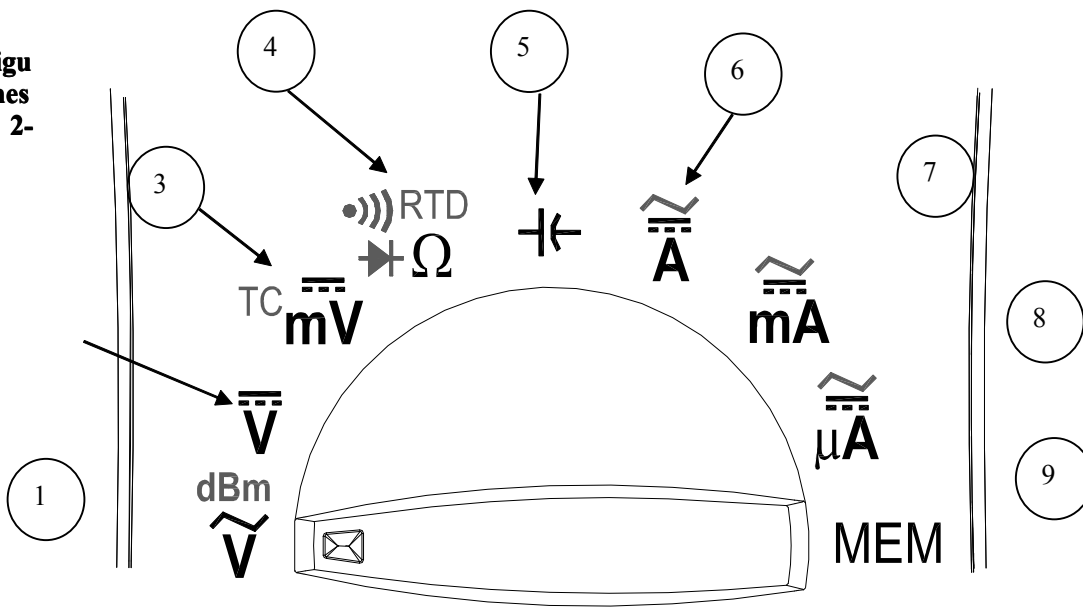

NO	Position	Rotary Switch Function	Blue Pushbutton Function
①	\widehat{V} dBm	AC Voltage Measurement	dBm Measurement
②	\overline{V}	DC Voltage Measurement	None
③	TC \overline{mV}	DC mA Voltage Measurement	TC Measurement
④	$\overline{\Omega}$ RTD	Resistance Measurement	Diode testing, continuity testing, RTD testing
⑤	\overline{C}	Capacitance	None
⑥	\overline{A}	Direct current measurement	Alternating current measurement
⑦	\overline{mA}	Direct current measurement	Alternating current measurement
⑧	$\overline{\mu A}$	Direct current measurement	Alternating current measurement
⑨	MEM	Read or clear the stored data in the meter. See Chapter 4 for the detailed information	None

Figure 2-4. Display Unit

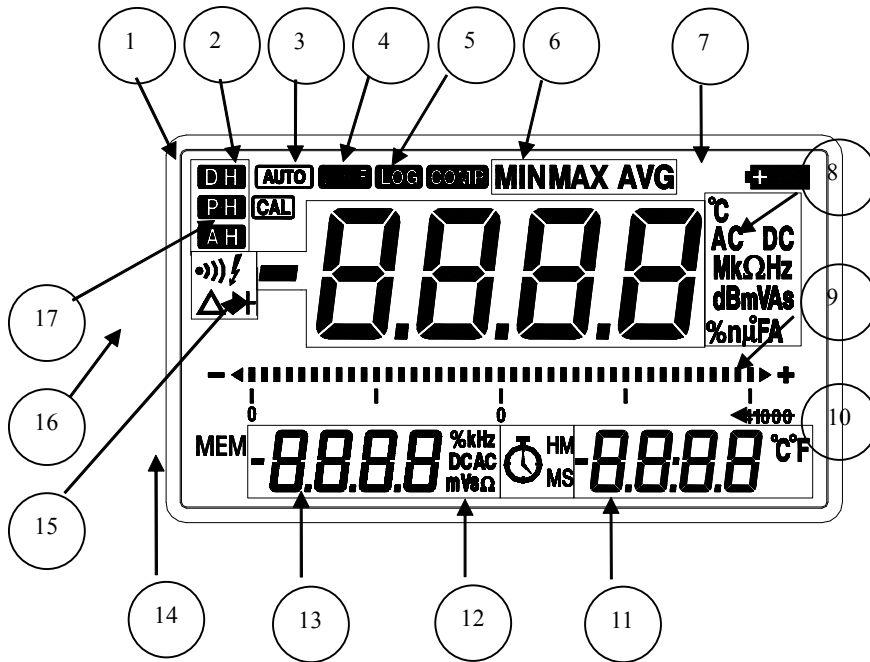

Table 2-3. Display Unit

No.	Unit	Meaning
①	DH PH AH	Display Hold: To hold present value in the main display Peak Hold: Valid only in DCV position Auto Hold: To freeze the present value in auto hold mode
②	AUTO	Toggles in auto-ranging mode
③	2ndF	To access yellow button () function
④	LOG	Readings are being recorded in logging mode
⑤	COMP	Readings are being recorded in comparative mode
⑥	MIN MAX AVG	Min. Max. Avg. Limited value measurement, primary display shows MIN、MAX、AVG value in cycle while secondary display shows present reading.
⑦	+	Low battery indicator. The indicator + in the display notifies you that the batteries are low and should be replaced. ⚠Warning To avoid false readings, which could lead to possible electric shock or personal injury, replace the batteries as soon as the low battery indicator + appears.

Table 2-3. Display Unit (Cont.)

No.	Unit	Meaning
⑧	Ω, kΩ, MΩ	The unit of resistance: Ohm, Kilohm, Megohm.
	Hz, kHz, MHz	The unit of frequency: Hertz, Kilohertz, and Megahertz.
	A, mA, μA	The unit of current: Amperes (amps), Milliamp, Micro amp.
	V, mV	The unit of voltage: Volt, Mill volt
	nF, μF	The unit of capacitance: Nanofarad, Microfarad, Millifarad.
	° C, ° F	Degrees Celsius (default) or Fahrenheit.
	dBm	For ac volts functions, reading is shown in decibels of power above or below 1 mW (dBm).
	AC DC	Alternating current, direct current.
	%	Display the duty cycle ratio of signals when measuring frequency.
⑨		Bar Graph The polarity indicator both ends of the bar graph show the polarity of the input; the arrow right of the bar graph indicates an overload condition.
⑩	41000	Range display. Digits display range in use.
⑪	-8.888 ^{CF} %	Time displays. In addition, it could be used to temperature display as well. Unit displays.

Table 2-3. Display Unit (cont.)





NO.	Unit	Meaning
⑫		Elapsed Time Display
⑬	-8.888	Secondary Display, and could be used to show the sequence number of the stored information.
	%kHz DCAC mVΩ	Unit Display of the secondary display
⑭	MEM	Readings are being recorded in manual stored mode
⑮	-8.888	Primary Display (3 3/4 digital)
⑯		Continuity test function is selected.
		>30 V ac and/or dc may be present at the input terminals
		Relative measured value
		Diodes Test
⑰	CAL	In Calibration mode

Figure 2-5. Pushbutton

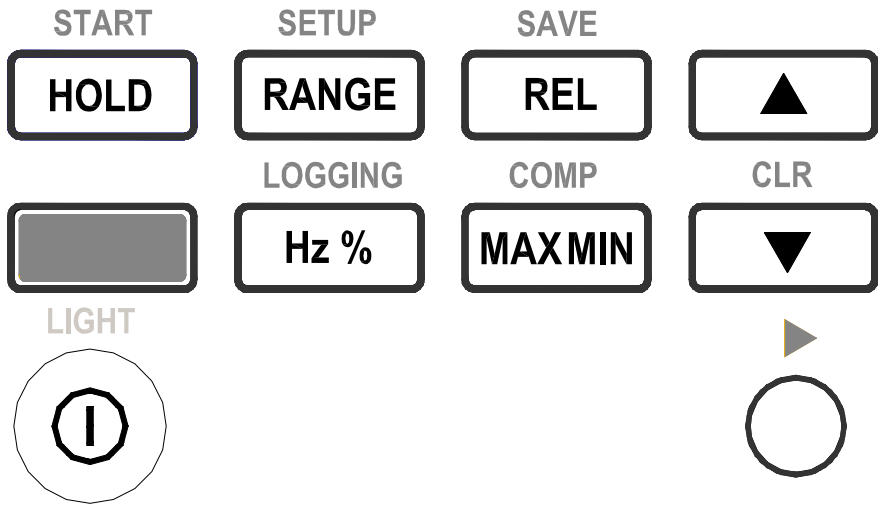





































Table 2-4.Pushbutton

Pushbutton	Description	Yellow Button Function	Description
<i>Note</i> Press  to access "Yellow Button Functions", and  will be on display			
	Press to access blue functions on the rotary switch. In Setup and Comparative Mode, use arrow function() function to select the next digit	(None)	
	In measuring mode, selects between the D.H, A.H and P.H functions. To cancel functions, press this key once again. In Logging mode or Comparative mode, press  to start storage function.	(None)	
	In measuring mode, press  to exit auto-ranging and enter manual ranging. In manual, select next input range. In Comparative mode, press  to set MAX and MIN value. Press  to enter Setup mode when turning the meter on, and press  to select the set value in the mode.	(None)	
	In measuring mode, press  to store the present reading as an offset reference; subsequent readings show only the relative difference from this value. In MEM mode, press  to read the Save Data.	 	Enter SAVE mode. In SAVE mode, press  to save present value. Press for more than 2 seconds to exit.
	In Setup or comparative mode, increment a digit. In MEM mode to read the display value, press  to get the previous record.	 	In measuring mode, press   to return to AUTO ranging.
	In measuring mode, successively press  to select frequency, duty cycle ratio, and voltage (current) in Voltage and Current position(except DC mV function) In MEM mode, press  to read LOGGING Data.	 	Enter LOG mode. Press for more than 2 seconds to exit.
	In measuring mode, press  to start retaining min, max, and average values. Press successively to display MAX, MIN, and AVG value. Press for more than 2 seconds to stop. In MEM, press to read COMP Data.	 	Enter SAVE mode. Press for more than 2 seconds to exit.
	In Setup or COMP mode, decrement a digit. In MEM mode, press to get the next data stored otherwise to clear off the data if pressing for more than 2 seconds	(None)	
	Turn on the power or backlight. Press for less than 2 seconds to turn on or off the backlight and more than 2 seconds to power off.	(None)	

Using Hold Mode

In the measuring mode, use  to select Display Hold, Auto Hold or Peak Hold. Press again to exit. The above three functions are not available when recording data.

● **Display Hold Mode (D.H)**

The primary display preserves the present value, and displays “” (see Figure 2-6).

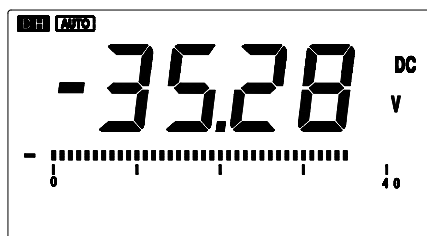

Figure 2-6. D.H Mode

In MAX, MIN mode, no further minimum, maximum, or average updates occur while the HOLD mode is enabled.

- **Auto HOLD Mode (A.H)**

⚠ Warning

Auto HOLD mode does not capture unstable or noisy readings. Do not use Auto HOLD mode to determine that circuits are without power.

Auto HOLD mode freezes the present reading in the primary display (The “AH” is displayed). New readings now appear in the secondary display. See Figure 2-7. When the meter detects a new, stable reading (>10% change from last stable reading), it beeps and displays the new reading in the primary display.

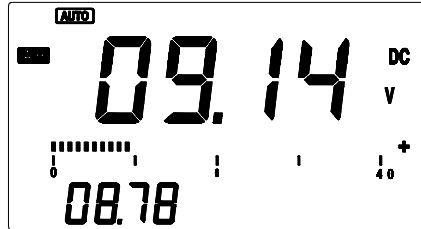

Figure 2-7. A.H Mode

If you remove the test leads (open the input), the meter retains the last frozen primary display.

You cannot initiate Auto HOLD while MAX MIN, REL, TC, RTD, dBm, DC mV, AC mV, Diodes, continuity, Capacitance, Frequency, or Duty cycle ratio function is active.

- **Peak HOLD Mode (A.H)**

Note

Peak HOLD mode is only available in (DCV) \overline{V} .

In Peak HOLD mode, the meter detects, refresh, and displays the peak value in DCV \overline{V} and display “PH”. (See figure 2-8).

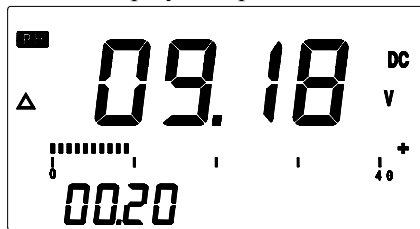

Figure 2-8.P.H Mode

Peak HOLD mode could capture the signals of an imminent of a positive polarity as short as 1 ms except that the accuracy is low.

In Peak HOLD mode, press $\overline{\text{SAVE/REL}}$ to calculate the relative value and the screen will show symbol “Δ” and the relative peak value.

Press $\overline{\text{CLR}}$ to clear the value off and the new peak value would be captured.

Using Relative Mode (REL)

In measurement mode, press $\overline{\text{SAVE/REL}}$ enter into relative mode and the meter displays the present reading as a reference in the secondary display and the relative value in the primary display (The difference between the reference and a new measurement).

Press $\overline{\text{SAVE/REL}}$ again to exit the mode.

This function is available with all functions except frequency/duty cycle ratio, MAX MIN, TC, RTD, dBm measurement.

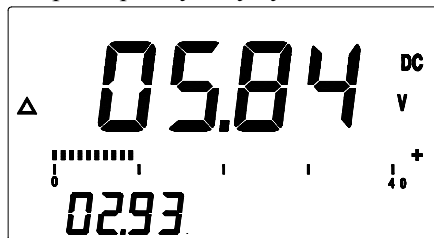



Figure2-9.Relative Mode



⚠ Warning

Do be careful for the possible dangerous voltage in the relative mode.



Selecting the Range

Press  to select a fixed range.

Auto ranging (“”)lighted in the display) always comes on initially when you select a new function. In auto range, the meter selects the lowest input range possible, ensuring that the reading appears with the highest available precision (resolution).

If AUTO is already on, press  to enter MANUAL ranging in the present range. You can then select the next manual range each time you press . Return to auto ranging by pressing .

Note



You cannot use  in conductance, diode test, or with the TC, RTD, and MAX MIN features. These selections all have a specific fixed range. You cannot use  in the capacitance and frequency measurement functions, which have Auto ranging only. DC mV has manual ranging only.

Using MIN MAX Mode

Note

The function is invalid in REL, TC, RTD, dBm, DC mV, Diodes, Continuity, Capacitance, Frequency, Duty cycle ratio features.

The MIN MAX mode stores minimum (MIN) and maximum (MAX) input values. MIN MAX mode also calculates an average (AVG) of all readings taken since the mode was activated. When the input goes below the stored minimum value or above the stored maximum value, the meter beeps and stores the new value. In addition, the meter displays the present measurement value in the secondary display and the new value in the primary display.

Press  the MAX, MIN and AVG value will be stored as the present displaying reading, and “MAX” will be on display first. Each subsequent press of  steps through the minimum (MIN), average (AVG) and back to the maximum reading.



The Auto Ranging will be shut off and fixed the present range before enter max min mode. Therefore, set the right range before choose this mode.

To exit this mode, press  for more than 2 seconds or set the rotary switch to any other position.

Chapter 3

Making Measurements

Introduction

Chapter 3 explains how to make measurements.

Most measurement functions can be selected by using the rotary switch.

White letters or symbols identify primary functions; blue letters or symbols identify alternative functions. Press the blue button to access these alternate functions. Frequency-related functions can be selected when the rotary switch is in any of the $\overset{dBm}{\sim}V$, $\overline{\sim}V$ or $\overset{dBm}{\sim}A$, $\overset{dBm}{\sim}mA$, $\overset{dBm}{\sim}\mu A$ position.

Measuring Voltage

Voltage is the difference in electrical potential between two points. The polarity of ac (alternating current) voltage varies over time, while the polarity of direct current voltage is constant over time.

Ranges available in volts functions are:

- $\overset{dBm}{\sim}V$
400.0mV, 4.000V, 40.00V, 400.0V, 750V
- $\overline{\sim}V$
4.000V, 40.00V, 400.0V, 1000V
- $\overset{TC}{mV}$
40.00mV, 400.0mV

Measuring AC Voltage (See Figure 3-1)

1. Set the rotary switch to $\overset{dBm}{\sim}V$ position, and “AC” “V” will be on display.
2. Insert the black lead into” COM “terminal, and the red lead to into the “ $\Omega \rightarrow V$ ” terminal.
3. Connect the leads to the testing power.
4. Read the measuring results from the screen.
5. Press $\overset{LOGGING}{Hz\%}$ to display the frequency and duty cycle ratio of the tested signals.

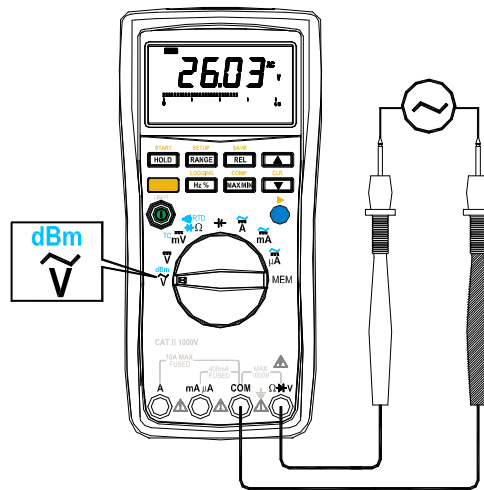

Figure 3-1.AC Voltage Measurement

⚠Warning

- Do not apply more than DC 1000 V or AC 750 rms voltage; the meter will possible be damaged though the value could be displayed.
- Indicator “ f ” is on display for safety note when 30 V ac and/or dc voltage present at the input terminals
- The meter beeps constantly if the input voltage is more than AC 750V rms, which is over the meter’s range.

dBm Measurements in AC Volts Functions(See Figure 3-2)

The ac volts functions allow you to display readings as deviations in dB (decibels) above or below an established level. Set up dB measurements with the following procedure:

1. Make an ac volt measurement to be used as a reference point.
2. Press dB to select dB. The dBm value appears in the primary display and the ac volts reading appears in the secondary display.
3. Press dB again to turn dB off.

Normally, dB is measured as dBm, which is a measure of decibels relative to 1 milliwatt. The meter assumes a resistance of 600 Ω in making this calculation. This resistance can be set for any value for 50 Ω , 75 Ω , 93 Ω , 100 Ω , 150 Ω , 300 Ω , 600 Ω , 800 Ω , 1200 Ω , 2400 Ω , using the meter’s setup capabilities (see Chapter 5.) to change the resistance.

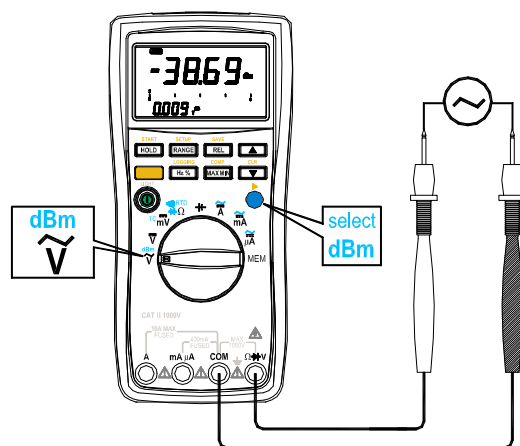

Figure 3-2.dBm Measurements

Note

If dBm is displayed, check that the reference resistance value closely matches the impedance of the system being measured.

dB is calculated with the following formula:

$$dBm = 20 \times \log_{10} \left(\frac{V_x}{V_r} \right)$$

- For dBm, V_r is the voltage across the reference resistance at 1mW. For example, V_r would be 0.7746 V with a 600- Ω reference resistance.

Measuring DC Voltage (See Figure 3-3)

1. Set the rotary switch to \overline{V} position, and “DC”, “V” will be on display.
2. Insert the black lead into “COM” terminal, and the red lead to into the “ $\Omega \rightarrow V$ ” terminal.
3. Connect the leads to the tested power.
4. Read the measuring results from the screen.

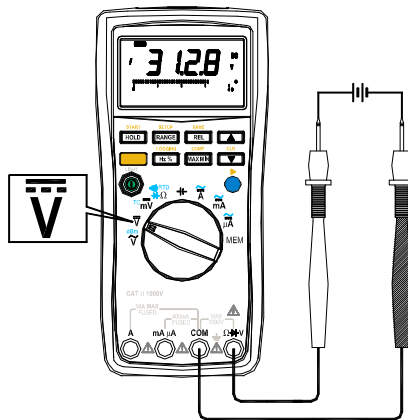

Figure3-3.DC Voltage Measurement

⚠ Warning

- Do not apply more than DC 1000 V or AC 750 rms voltage; the meter will possible be damaged though the value could be displayed.
- Indicator “⚡” is on display for safety note when 30 V ac and/or dc voltage present at the input terminals
- The meter beeps constantly if the input voltage is more than AC 750V rms, which is over the meter’s range.

Measuring DC mV Voltage (See Figure 3-4)

1. Set the rotary switch to $TC \overline{mV}$ position, and “DC” “mV” will be on display.
2. Insert the black lead into “COM” terminal, and the red lead into the “ $\Omega \rightarrow V$ ” terminal.

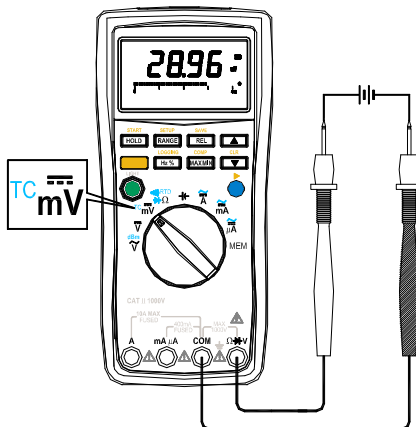

Figure3-4.DC mV Measurement

3. Connect the leads to the tested power.
4. Read the measuring results from the screen.

Measuring TC

1. Set the rotary switch to $TC \overline{mV}$ position, and press blue button (ⓘ) to select TC measurement.
2. Insert TC into “COM” and “ $\Omega \rightarrow V$ ” terminals, make sure the TC jack with symbol “+” is connected into the “ $\Omega \rightarrow V$ ” terminal.
3. Read the measuring results from the screen.

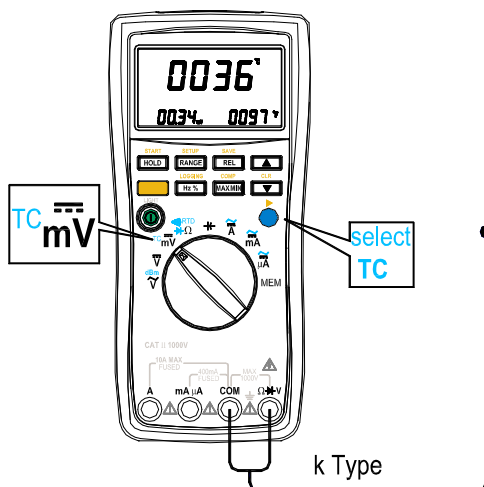

Figure3-5.TC Measurement

The temperature degree is shown on the primary display, the TC value on the secondary display and Fahrenheit degree on elapsed time display.

When the output jack is open circuit, the screen displays OL.

⚠ Warning

To avoid possible electric shock or personal injury, do not connect the TC with the live circuit.

Measuring Resistance (See Figure3-6)

⚠ Warning

To avoid possible damage to the meter or to the equipment under test, disconnect circuit power and discharge all high-voltage capacitors before measuring resistance.

The meter's resistance ranges are 400.0Ω, 4.000KΩ, 40.00KΩ, 400.0KΩ, 4.000MΩ and 40.00MΩ.

To measure resistance, proceed as follows:

1. Set the rotary switch to  Ω position (Default value in this function)
2. Insert the black lead into "COM" terminal, and the red lead to into the " $\Omega \rightarrow V$ " terminal.
3. Connect the leads to the tested power.
4. Read the measuring results from the screen.

⚠ Caution

- "OL" appears on the display if the resistance under test is open or the value surpasses the maxim range.
- The test lead can add 0.1Ω to 0.2Ω of error to resistance measurements. To test the leads, touch the probe tips together and read the resistance of the leads. If necessary, you can press  to automatically subtract this value.
- Wait for several seconds for stable reading when measuring resistance more than 1MΩ.

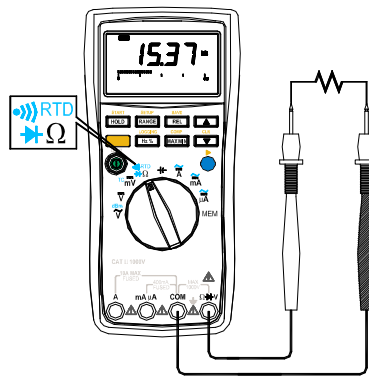

Figure3-6.Resistance Measurement



Testing Diodes (See Figure3-7)

⚠ Warning

To avoid possible damage to the meter or to the equipment under test, disconnect circuit power and discharge all high-voltage capacitors before testing diodes.

Use the diode test to check diodes, transistors, and silicon-controlled rectifiers (SCR), and other semiconductor devices. The test sends a current through a semiconductor junction, and then measures the junction's voltage drop. A typical junction drops 0.5 V to 0.8 V.

To test a diode, proceed as follows:

1. Set the rotary switch to  Ω position, and press blue button () to select diodes testing, and the symbol " \rightarrow " will be shown on the left part of the screen.
2. Insert the black lead into "COM" terminal, and the red lead to into the " $\Omega \rightarrow V$ " terminal. The polarity of the black lead and red lead is "-" and "+" respectively.

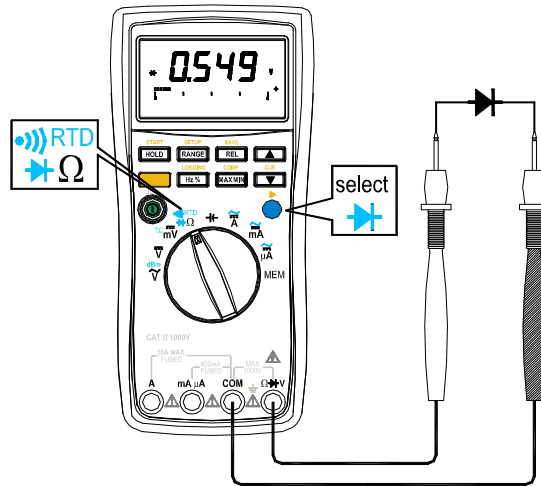

Figure3-7. Diode Test

In a circuit, a similar diode should still indicate a forward bias reading of 0.5 V to 0.8 V; however, the reverse-bias reading can vary depending on the resistance of other pathways between the probe tips.

Note

In the live diodes testing, the resistance of other pathways and between the probe tips will affect the reading of reverse-bias voltage.

Testing for Continuity (See Figure3-8)

Warning

To avoid possible damage to the meter or to the equipment under test, disconnect circuit power and discharge all high-voltage capacitors before testing for continuity.

Continuity is the presence of a complete path for current flow. The continuity test features a beeper that sounds if a circuit is complete. The beeper allows you to perform quick continuity tests without having to watch the display.

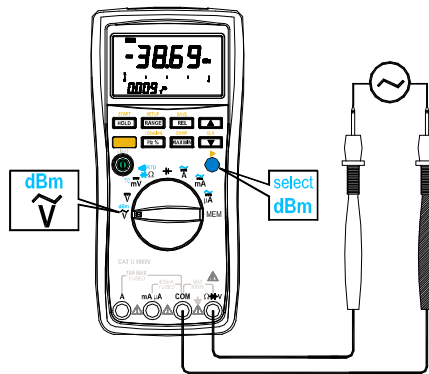

See Figure3-8. Continuity Test

To test continuity, proceed as follows:

1. Set the rotary switch to $\Omega \rightarrow V$ position, and press blue button (ⓘ) twice to select **continuity check** and the symbol “(•)”) will be shown on the left part of the screen.
2. Insert the black lead into “COM” terminal, and the red lead to into the “ $\Omega \rightarrow V$ ” terminal.
3. Connect the leads to the two ends of the tested circuit.
4. The inner beeper sounds when the tested circuit resistance is less than 50Ω, which indicates the circuit is through.

Measuring RTD (See Figure3-9)

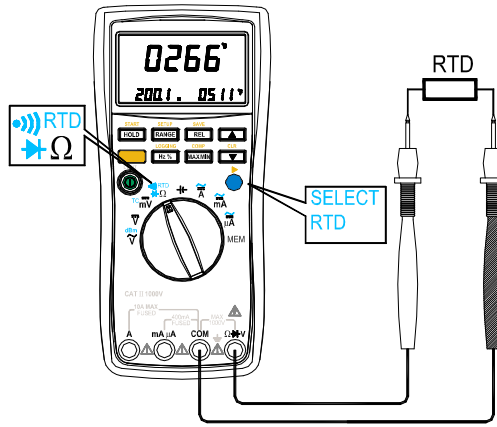

See Figure3-9.RTD Measurement

1. Set the rotary switch to Ω position, and press blue button (SELECT RTD) three times to select diodes testing.
2. Insert the black lead into “COM” terminal, and the red lead to into the “ $\Omega \rightarrow V$ ” terminal.
3. Connect the leads to the tested RTD.
4. Read the measuring results from the screen.

Measuring Capacitance (See Figure3-10)

Warning

To avoid possible damage to the meter or to the equipment under test, disconnect circuit power and discharge all high-voltage capacitors before measuring capacitance. Use the dc voltage function to confirm that the capacitor is discharged.

The meter’s capacitance ranges are 50.00nF、500.0nF、5.000 μ F、50.00 μ F、100.0 μ F.

To test capacitance, proceed as follows:

1. Set the rotary switch to C position to select capacitance measurement.
2. Insert the black lead into “COM” terminal, and the red lead to into the “ $\Omega \rightarrow V$ ” terminal.
3. Connect the leads to the tested capacitance.
4. Read the measuring results from the screen.

Caution

- OL appears on the display if the tested capacitance is open or the value surpasses the maxim range.
- If the tested capacitance is polar capacitance, then connect the red lead with the positive point and the black lead with the negative point.
- High capacitance test needs more time, and 30s is necessary in 100 μ F position.
- To improve the measurement accuracy of small value capacitors, press **SAVE REL** with the test leads open to subtract the residual capacitance of the meter and leads.
- The remaining voltage of capacitance, insulated impedance and dielectric absorption could cause measuring errors.
- Only Auto ranging mode is available in capacitance measurement.

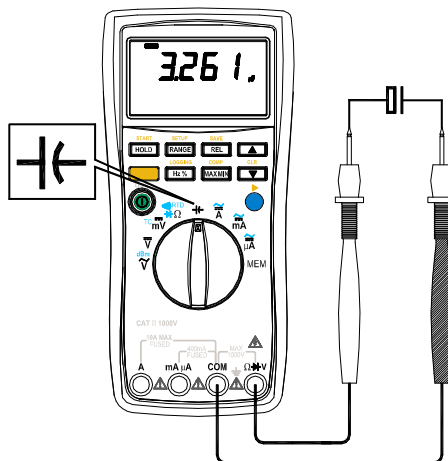

See Figure3-10. Capacitance Measurement

Measuring Current (See Figure3-11, Figure3-12)

Warning

- Never attempt an in-circuit current measurement where the open-circuit potential to earth is greater than 1000 V. You may damage the meter or be injured if the fuse blows during such a

measurement.

- You must open the circuit under test, then place the meter in series with the circuit.

⚠Caution

To avoid possible damage to the meter or to the equipment under test, check the meter's fuses before measuring current. Use the proper terminals, function, and range for your measurement. Never place the probes across (in parallel with) any circuit or component when the leads are plugged into the current terminals.

To measure ac or dc current, proceed as follows:

1. Insert the black lead into the COM terminal. Insert the red lead in an input appropriate for the measurement range as shown in Table 3-1.
2. When using **A** jack, set the rotary switch on **A** position; When using **mA** **μA** jack, set the rotary switch on **μA** position if the current is less than 4000μA and **mA** position if the current is more than 4000μA.
3. The meter is preset to direct current, and the screen shows "DC"; Press blue pushbutton (ⓘ) once to select alternating current measurement and the screen shows "AC".
4. Open the circuit path to be tested. Touch the red probe to the more positive side of the break; touch the black probe to the more negative side of the break. Reversing the leads will produce a negative reading, but will not damage the meter.
5. Turn on power to the circuit, and read the measuring results from the screen.
6. Press **LOGGING** **Hz %** to toggle between the frequency and duty cycle ratio of the signals under test.
7. Turn off power to the circuit and discharge all high voltage capacitors. Remove the meter and restore the circuit to normal operation.

Table 3-1.Current Measurement

Rotary Switch	Input	Ranges
	A	4.000A 10.00A
	mA	40.00mA 400.0mA
	μA	400.0μA 4000μA

⚠Notice

- Start measuring from the high range if the current can't be evaluated.
- For safety, the measuring time should be limited within 15s, while the interval should be more than 10 min when measuring high current. If the input current is more than 10.00A, then the inner beeper sounds constantly indicating the value surpass the range.

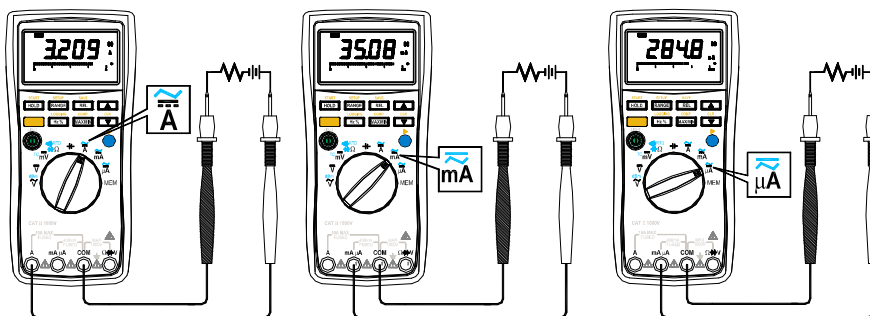

Figure3-11.DC Current Measurement

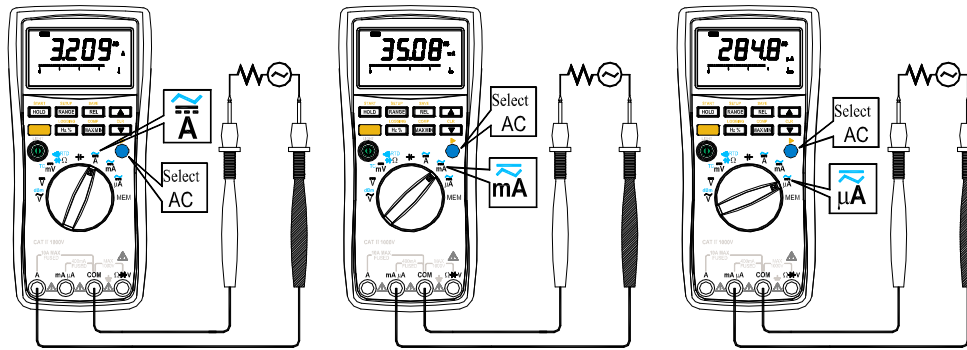



Figure3-12.AC Current Measurement

Measuring Frequency and Duty cycle ratio (See Figure3-13)

In voltage and current (DC mV excluded) measurement, press  to display frequency → duty cycle ratio → voltage (current), frequency, duty cycle ratio, and then back to voltage (current).

Frequency → Duty cycle ratio → Voltage (Current) → Voltage (Current) → Frequency
 Frequency Duty cycle ratio

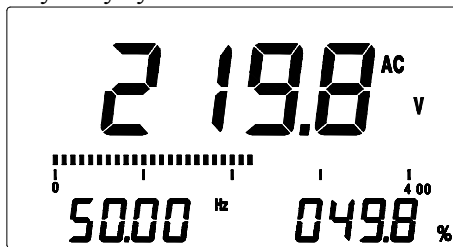

Figure3-13.Frequency and Duty cycle ratio

⚠ Notice

Please select the proper range in voltage or current function before measuring frequency and duty cycle ratio.

Chapter 4

Using Memory & Communications Features

Introduction

Chapter 4 shows you how to use memory and communication features available on the meters.

Data Storage

The meter has three types of memory data: SAVE mode, LOG mode and COMP mode.

△Notice





- Undertake “clearing memory data” operation first if the date storage functions are used firstly.
- The date storage mode is unavailable when the meter is in D.H, A.H, P.H, Hz% or MAX MIN function. The COMP mode is unavailable when measuring capacitance. The range cannot be changed when the date storage functions are active.
- In MEM position, “- - -” on the screen indicates data storage is empty and could save the data; “FULL” on the screen indicates data storage is full and will stop saving.
- In LOG or COMP mode, no data could be saved if there is a recording (no matter the storage is full or not). The user should clear off the memory and then start to save. In LOG or COMP mode, the meter will return to measuring mode when the storage is full.
- Low battery indicator  Appears on the screen to indicating forbid saving.

Table 4-1.Memory Capacity

Memory Mode	Memory Capacity
SAVE mode	500
LOG mode	1000
COMP mode	1000



SAVE Mode

Proceed as follows:







1. Press  to save reading, “MEM” appears in the display and record number is displayed in the secondary display, the meter enters into SAVE mode.
2. Press  to save present value in the memory and the record number increments by one.
3. Press  for more than 2S or set the rotary switch to any other position to exit the SAVE mode.

LOG Mode

Proceed as follows:

1. Set the starting time and interval time of the real time data (see “Changing the Default Settings”).
2. Press , “LOG” appears on the screen and the recorded number appears in the secondary display; the elapsed time display shows the time and the meter enters into LOG mode.
3. Press  to start log mode, and counts the time. On the starting time, the meter begins to store the data in the Logging Saving Memory. The meter exits the mode automatically when the storage is full.
4. Press  for more than 2S or change the rotary switch position to exit the mode.

COMP Mode

1. Press , “COMP” appears on the screen and the record number appears in the secondary display; the elapsed time display shows the time and the meter enters into COMP mode.
2. Set the upper and lower limits. Press  to set the upper limit and “MAX” appears on the screen, and the digit set part in the primary display flashes. Press the blue button to select the set digits. Use  or  to change the numerical value of the set digits. Press  again to set the lower limit and “MIN” displays. The setting way of the lower limit is same as that of the upper limit. Press for the third time to save the set data.
3. Press  to start COMP mode. If you do not undertake step 2, then the default values of the upper and lower limits are zero. Pressing  is invalid when setting the upper and lower limit values.

Viewing Memory Data

Use the following procedure to view memory data:





1. Disconnect the input leads at the measurement source.

△Warning

To avoid electric shock, disconnect the test leads when the rotary switch is in the MEM position.

△Notice

In MEM function, each operation could only read or clear the data of one storing part.

2. Turn the rotary switch to the MEM position and “**READ**” displays on the screen.
3. Press pushbutton to select a storing data.
Press  for saved reading, “**MEM**” appears in the display.
Press  for logged reading, “**LOG**” appears in the display.
Press  for comparative reading, “**COMP**” appears in the display.
4. Press  or  to view the sequent or the previous recording.
5. Turn the rotary switch to any other position to enter measuring mode.

Clearing Memory

Use the following procedure to clear memory data:







1. Disconnect the input leads at the measurement source.

Warning

To avoid electric shock, disconnect the test leads when the rotary switch is in the MEM position.

Notice

In MEM function, each operation could only read or clear the data of one storing part.

2. Turn the rotary switch to the MEM position.
3. Press pushbutton to select a storing data to clear.
Press  to clear saved reading, “**MEM**” appears in the display.
Press  to clear logged reading, “**LOG**” appears in the display.
Press  to clear comparative reading, “**COMP**” appears in the display.
4. Press  for more than 2S, “**CLR**” appears in the display and press  again to clear the type of memory presently; or else press  to cancel.

Using Communications

Notice

Make sure your PC has been connected with the earth ground when employing this function.

When using a PC-to-meter IR (infrared) communication link, refer to the DMMVIEW_A Software Guide or the on line help. You can use the USB to UART Bridge Controller and DMMVIEW_A software to transfer the contents of a meter to a PC.

Chapter 5

Changing the Default Settings

Introduction

The meter allows you to change the default-operating configuration of the meter by changing setup options made at the factory. Many of these setup options affect general meter operations and are active in all functions. Others are limited to one function or group of functions.

Selecting Setup Options

To enter the Setup mode, turn the meter on and press **SETUP** [RANGE].

In the Setup mode, each setup option appears in the secondary display and the default value appears in the primary display.

Press **SETUP** [RANGE] to change the setup option. Press **SAVE** [REL] to store the set value (SAVE on the primary display indicates the maintained item has been stored).

To exit the Setup mode, power off.

Table 5-1.Changing the Default Settings

Selection		Function	Factory Default
APDF	Power off time	Set Range: 0 to 60min, ±10min for each change. Set zero to cancel auto power-off function. Use CLR or ▲ to increment or decrement digit.	10 minutes
BLDF	Backlight time	Set Range: 0 to 9000s, ±30s for each change. Set zero to cancel auto backlight function. Use CLR or ▲ to increment or decrement digit.	30 seconds
ENOS	dBm reference value	Use CLR or ▲ to select reference value: 50Ω, 75Ω, 93Ω, 100Ω, 150Ω, 300Ω, 600Ω 800Ω, 1200Ω, 2400Ω	600Ω
SEAT	LOG mode starting time	Set Range: 0 to 3000 min. Press blue button () to select the set digits. Use CLR or ▲ to change the numerical value of the set digits.	0 minute
INTE	LOG mode interval time	Set Range : 0 to 7200S. Press blue button () to select the set digits. Use CLR or ▲ to change the numerical value of the set digits.	1 second
LILI	COMP mode selection	Set upper or lower outer save value (YES) or upper or lower inner (NO) save value. Use CLR or ▲ to select.	NO
FCLY	Restore factory default	Press SAVE [REL], “ SAVE ” appears in the primary display to indicate return to the factor default.	----

Chapter 6

Maintenance

Introduction

This section provides some basic maintenance procedures. Repair, calibration, and servicing not covered in this manual must be performed by qualified personnel. For maintenance procedures not described in this manual, contact a Service Center.

General Maintenance

- Periodically wipe the case with a damp cloth and mild detergent. Do not use abrasives or solvents.
- Take off the battery if you will not use the meter for a long time.
- Dirt or moisture in the terminals can affect readings and can falsely activate the Input Alert feature. Clean the terminals as follows:

1. Turn the meter off and remove all test leads.
2. Shake out any dirt that may be in the terminals.
3. Soak a new swab with alcohol. Work the swab around in each terminal.

Testing the Fuses

⚠ Warning

To avoid electrical shock or personal injury, remove the test leads and any input signals before replacing the battery or fuses. To prevent damage or injury, install ONLY specified replacement fuses with the amperage, voltage, and speed ratings.

To check the fuse, proceed as follows:

1. Set the rotary switch on **\overline{mA}**
2. Insert the black lead to COM jack and red lead to **\overline{mA}** jack.
3. Using an ohmmeter, check the resistance between the meter tested leads .If the resistance is about 1Ω , the fuse is good. An open reading means that fuse F1 is blown.
4. Set the rotary switch on **\overline{A}** .
5. Insert the black lead to COM jack and red lead to **\overline{A}** jack.
6. Using an ohmmeter, check the resistance between the meter tested leads .If the resistance is about 0.01Ω , the fuse is good. An open reading means that fuse F2 is blown

Table 6-1.Fuse Specifications

F1	10A/250V FAST $\Phi 6 \times 25\text{mm}$
F2	0.5A/250V FAST $\Phi 5 \times 20\text{mm}$

Replacing the Fuses

Δ Warning

To avoid electrical shock or damage to the meter, only use replacement fuses specified in Table 6-1.

Referring to Figure 6-1, replace the meter's fuses as follows:

1. Turn the rotary switch to OFF and remove the test leads from the terminals.
2. Take off protector of the meter. Then remove the battery access door by using a standard-blade screwdriver to turn the battery door screws one-quarter turn counterclockwise.
3. Remove either fuses by gently prying one end loose, then sliding the fuse out of its bracket.
4. Install ONLY specified replacement fuses with the amperage, voltage, and speed ratings.
5. Reinstall the battery door. Secure the door by turning the screws one-quarter turn clockwise.
6. Reinstall the meter's protector.

Replacing the Batteries

The meter needs four AAA alkaline batteries.

Δ Warning

To avoid electrical shock:

- **Remove test leads from the meter before opening the battery door.**
- **Close and latch the battery door before using the meter.**

Δ Notice

- **The new and old Batteries can not be mixed**
- **Take out the batteries if the meter won't be used for a long time**
- **Dispose the old batteries in accordance with the local law.**

Replace the batteries as follows. Refer to Figure 6-1

1. Remove the test leads and turn the meter OFF
2. Specific steps: take off the protector of the meter and then with a standard blade hand screwdriver, turn each battery door one-quarter turn counterclockwise, so that the slot is parallel with the screw picture molded into the case.
3. Replace the batteries and reinstall the battery door. Secure the door by turning the screws one-quarter turn clockwise.
4. Reinstall the meter's protector.

Δ Caution

Make sure the battery's odes are in accordance with the symbols illustrated in battery pool when replacing them.

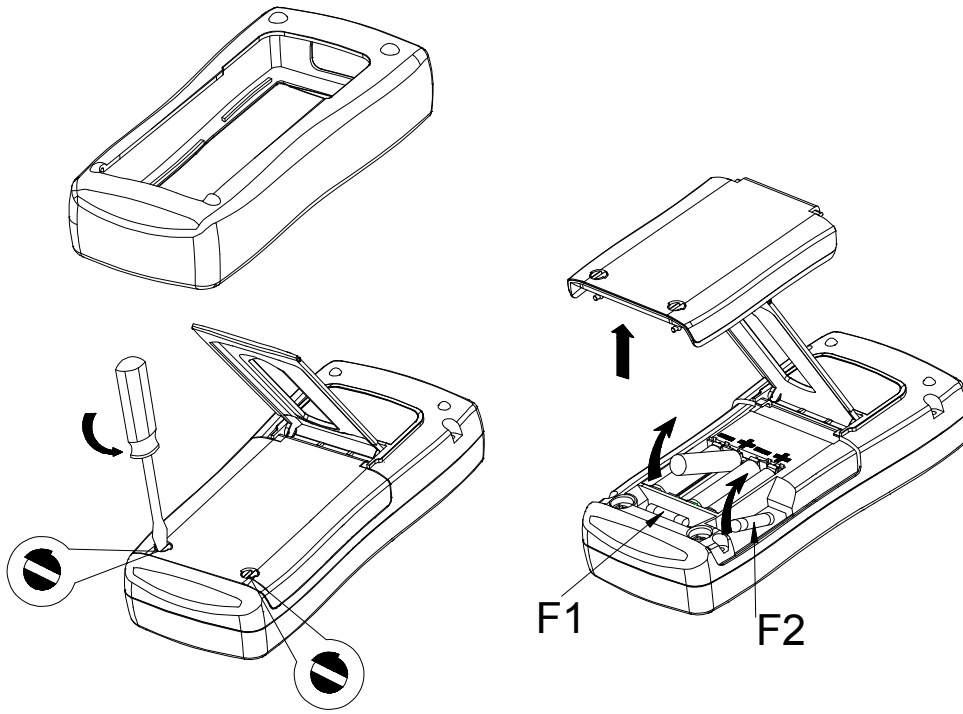

Figure 6-1. Battery and Fuse Replacement

Chapter 7 Specifications

Safety and Compliance

Highest voltage of all input jacks to earth ground	1000V dc or ac
Compliance	Complies with IEC61010.1-93 Over voltage II Pollution Degree 2. (Safety Standard issued by IEC)
Fuse Protection for mA or μA inputs	0.5 A, 250 V FAST Fuse
Fuse Protection for A input	10 A, 250 V FAST Fuse

Physical Specifications

Basic Specifications

Display (LCD)	Digital: 4000 counts primary display; 4000 counts secondary display; updates 3/second. Analog: 41 segments, updates 10/second.
Operating Temperature	5 °C to + 50 °C
Storage Temperature	-10 °C to + 55 °C
Relative Humidity	0 °C to + 30 °C \leq 75% 30 °C to + 40 °C \leq 50%
Battery Type	4×AAA alkaline battery, NEDA, LR03
Size	205×95×42mm (plus protector)
Weight	About 500g (plus protector)
Calibration Interval	1 Year

Speci ons

Data Accuracy Specifications

All specifications apply to 10%R unless otherwise stated. All measurements are a 5-second average. Standby specifications for year. Accuracy

Function		Ranges/Description
DC Voltage		0 to 1000V
AC Voltage, averaging converter		0 to 750V
Basic Accuracy		DC Voltage: 0.2% AC Voltage: 0.5%
DC Current		0 to 10A(constant measurement shall be limited within 15s, and log less than 15min)
AC Voltage, averaging converter		0 to 10A(constant measurement shall be limited within 15s, and log less than 15min)
Resistance		0 to 40MΩ
Capacitance		0 to 100μF
Diodes		Open circuit Voltage: 1.1V to 1.6V Short circuit Voltage: less than 0.2mA(Typical Value)
Continuity		Beeps < 50Ω Open Circuit Voltage: < 0.45V Short Circuit Voltage: 130μA typical value
TC(K Type)Test		-200°C to 950°C (-328°F to 1472°F)
RTD(Pt100 Type)Test		-200°C to 700°C (-328 °F to 1292°F)
Frequency		0Hz to 100kHz
Reading Storage	Save mode	500
	Log mode	1000
	Comp mode	1000

Electrical Specifications

the measurements to +18 +28°C, to H stated wise. specifications assume minimum warm period. radiation valid one

accuracy

specifications are given as: ± ([% of reading] + [number of least significant digits])

Note

“Counts” refers to the number of increments or decrements of the least significant digit.

DC Voltage Measurement

Range	Resolution	Accuracy	Remark
40.00mV	0.01 mV	0.5%+6	Measuring Impedance: > 2.5GΩ Overvoltage Protection: 1000V
400.0mV	0.1 mV	0.2%+4	
4.000V	0.001V	0.2%+4	Measuring Impedance(Standard Value): 10 MΩ< 100 pF Common mode rejection ratio: 50Hz or 60Hz > 100dB Normal mode rejection ratio: 50Hz or 60Hz > 45dB Overvoltage: 1000 V
40.00V	0.01V	0.2%+4	
400.0V	0.1V	0.2%+4	
1000V	1V	0.5%+4	

AC Voltage Measurement

Range	Resolution	Accuracy (40~400Hz)	Remark
400.0 mV	0.1 mV	1.0%+4	Specifications are valid from 5% to 100% of amplitude range 400mV is only confined to manual range AC conversion: averaging converter Measuring Impedance: 10MΩ(Standard Value) < 100pF Common mode rejection ratio: 50Hz or 60Hz > 60dB Overvoltage protection: 1000V
4.000 V	0.001 V	0.5%+4	
40.00 V	0.01 V	0.5%+4	
400.0 V	0.1 V	0.5%+4	
750V	1V	0.5%+4	

DC Current Measurement

Range	Frequency	Accuracy	Remark
-------	-----------	----------	--------

400.0μA	0.1μA	0.2%+4	Measuring Impedance : 100Ω	Overvoltage protection : 0.5A/250V fast-blow fuse
4000μA	1μA	0.2%+4		
40.00mA	0.01mA	0.2%+4	Measuring Impedance:	
400.0mA	0.1mA	0.2%+4	1Ω	
4.000A	0.001A	0.5%+4	Measuring Impedance :	
10.00A	0.01A	1.0%+4	0.01Ω	Overvoltage protection : 10A/250V fast-blow fuse

AC Current Measurement

Range	Resolution	Accuracy (40~400Hz)	Remark	
400.0μA	0.1μA	0.5%+4	Measuring Impedance: 100Ω	Overvoltage: 0.5A/250V fast-blow fuse
4000μA	1μA	0.5%+4		
40.00mA	0.01mA	0.5%+4	Measuring Impedance: 1Ω	
400.0mA	0.1mA	0.5%+4		
4.000A	0.001A	1%+4	Measuring Impedance: 0.01Ω	Overvoltage: 10A/250V fast-blow fuse
10.00A	0.01A	1%+4		

Resistance Measurement

Range	Frequency	Accuracy	Remark
400.0Ω	0.1Ω	0.2%+4	Open circuit voltage: 0.4V Guide lead resistance is excluded in the accuracy Overvoltage protection: 1000V
4.000kΩ	0.001kΩ	0.2%+4	
40.00kΩ	0.01kΩ	0.2%+4	
400.0kΩ	0.1kΩ	0.2%+4	
4.000MΩ	0.001 MΩ	0.5%+4	
40.00 MΩ	0.01 MΩ	1%+4	

Capacitance Measurement

Range	Frequency	Accuracy	Remark
50.00nF	0.01nF	4%+5	To improve the accuracy of the low capacitance value, open the circuit, and then press  to automatically subtract the capacitance of the meter and the leads.
500.0nF	0.1nF	2%+5	
5.000μF	0.001μF	2%+5	
50.00μF	0.01μF	2%+5	
100μF	1μF	4%+5	

Frequency Count Accuracy

Function	Range	Resolution	Accuracy	Remark
Frequency	50.00Hz	0.01Hz	0.1%+3	Display updates 3 times/second (at >10Hz)
	500.0Hz	0.1Hz	0.1%+3	
	5.000KHz	1Hz	0.1%+3	
	50.00KHz	0.01KHz	0.1%+3	
	100.0 KHz	0.1KHz	0.1%+3	
Duty cycle ratio	0.1%~99%	0.1%	1%	

TC Measurement

Function	Input Range	Resolution	Accuracy	Remark
----------	-------------	------------	----------	--------

K	-200 to 950°C	1°C	0.5%+2(≤-100°C) 0.5%+1(> -100°C)	By using ITS-90 temperature scale Note: The accuracy does not include the error of internal temperature compensation caused by a sensor. The range of the internal temperature compensation sensor is ± 2°C.
---	---------------	-----	-------------------------------------	---

RTD Measurement

Function	Input Range	Resolution	Accuracy	Remark
Pt100	-200 to 700°C	1°C	0.5%+2	By using Pt100-385 temperature scale Measuring current 1mA Note: attached lead resistance is excluded

Diode Test

Range	Frequency	Accuracy	Short Circuit current	Open Circuit voltage
1.000V	0.001V	10%	Less than 0.2mA (typical value)	1.1V to 1.6V

Continuity Check

Range	Frequency	Accuracy	Short Circuit current	Open Circuit voltage
400.0Ω	0.1Ω	Beeps if the value is less than 50Ω	130μA (typical value)	< 0.45V

Peak hold

Range	Accuracy	Response time
DCV	±100 Counts	>1ms

Notice of the Instruction Manual

- The present operation instruction is subject to change without notice.
- The content of the operation instruction is regarded as correct. Whenever any user finds its mistakes, omission, etc., he or she is requested to contact the manufacturer.
- The present manufacturer is not liable for any accident and hazard arising from the customer misuse or inadvertent operation.
- The functions described in this operation instruction should not be used as grounds to apply this product to a particular purpose.